

FRONT VIEW

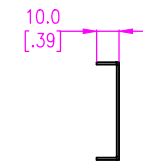

SIDE VIEW

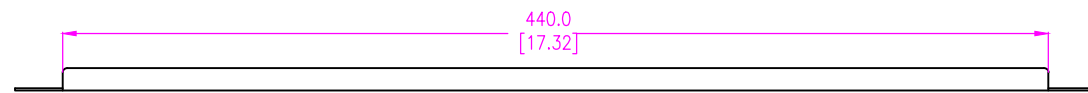

BOTTOM VIEW

ISOMETRIC VIEW

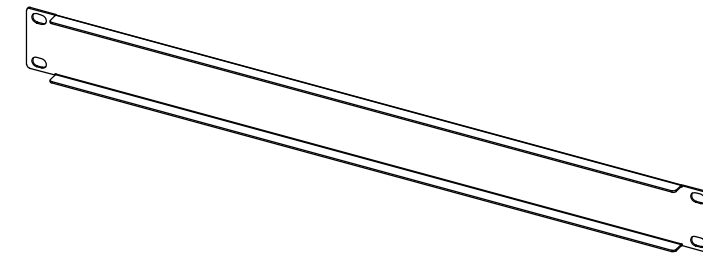

APPLICATION DETAILS

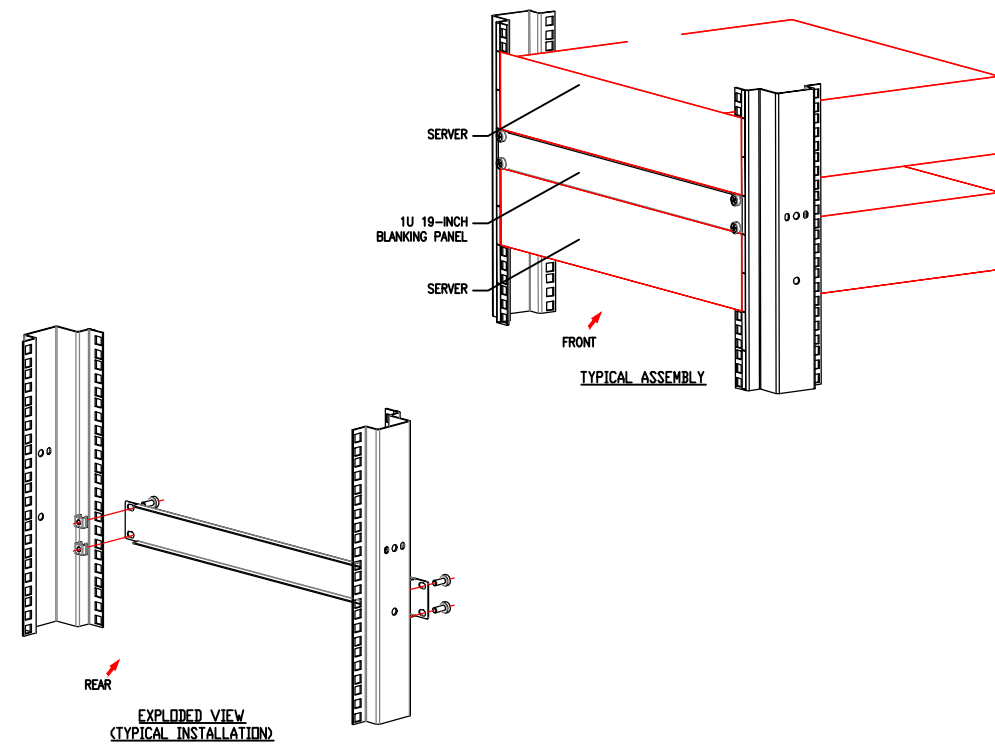

NOTES:

1. INSTALLATION SHALL COMPLY WITH ALL APPLICABLE NATIONAL AND LOCAL CODES.
2. SEE PRODUCT DOCUMENTATION FOR FURTHER INFORMATION.
3. UNLESS OTHERWISE SPECIFIED, ALL DIMENSIONS ARE IN INCHES [MILLIMETERS].
4. WEIGHT OF UNIT IS 0.48 LBS. [0.22 kg].
5. BLACK POWDER SPRAYING SURFACE, SCRATCH RESISTANT.

THIS DRAWING AND SPECIFICATIONS HEREIN ARE THE PROPERTY OF Rakworx AND SHALL NOT BE COPIED, REPRODUCED OR USED IN WHOLE OR IN PART, AS THE BASIS FOR THE MANUFACTURE OR SALE OF ITEMS WITHOUT WRITTEN PERMISSION FROM Rakworx. THIS DRAWING IS BASED UPON LATEST AVAILABLE INFORMATION AND IS SUBJECT TO CHANGE WITHOUT NOTICE.

Name	Date	Description	Drawing No.
Drawn by		MAIN MECHANICAL	RM89007-1
Approved by			Unit: mm
Rakworx		Scale: 1:1	Third angle projection Sheet: 10F1